



VISHAY INTERTECHNOLOGY, INC.

DATA BOOK



HIGH VOLTAGE POWER CAPACITORS

Vishay ESTA

Scope

Standards

Fields of Application

General Data

VISHAY INTERTECHNOLOGY, INC.

DISCRETE SEMICONDUCTORS

RECTIFIERS	Schottky (single, dual) Standard, Fast and Ultra-Fast Recovery (single, dual) Clamper/Damper Bridge Superectifier®
SMALL-SIGNAL DIODES	Schottky and Switching (single, dual) Tuner/Capacitance (single, dual) Bandswitching PIN
ZENER & SUPPRESSOR DIODES	Zener Diodes (single, dual) TVS (TransZorb®, Automotive, Arrays)
MOSFETs	Power MOSFETs JFETs
RF TRANSISTORS	Bipolar RF Transistors (AF and RF) Dual Gate MOSFETs MOSMICs®
OPTOELECTRONICS	IR Emitters, Detectors and IR Receiver Modules Opto Couplers and Solid State Relays Optical Sensors LEDs and 7 Segment Displays Infrared Data Transceiver Modules Custom products
ICs	Power ICs Analog Switches

PASSIVE COMPONENTS

CAPACITORS	Tantalum Capacitors Solid Tantalum Capacitors Wet Tantalum Capacitors Ceramic Capacitors Multilayer Chip Capacitors Disc Capacitors Film Capacitors Power Capacitors Heavy Current Capacitors Aluminum Capacitors
RESISTIVE PRODUCTS	Foil Resistors Film Resistors Thin Film Resistors Thick Film Resistors Metal Oxide Film Resistors Carbon Film Resistors Wirewound Resistors Variable Resistors Cermet Variable Resistors Wirewound Variable Resistors Conductive Plastic Variable Resistors Networks/Arrays Non-Linear Resistors NTC Thermistors PTC Thermistors
MAGNETICS	Inductors Transformers

INTEGRATED MODULES

DC/DC CONVERTERS	
-------------------------	--

MEASUREMENT SENSORS AND EQUIPMENT

STRAIN GAGES	Stress Analysis Transducer-Class® Installation Accessories
INSTRUMENTATION	Strain Indicators Amplifiers Data Systems
PHOTOSTRESS® PRODUCTS	Polariscopes Plastics
TRANSDUCERS	Load Cells Linear Displacement Sensors

ONE OF THE WORLD'S LARGEST MANUFACTURERS OF DISCRETE SEMICONDUCTORS AND PASSIVE COMPONENTS

High Voltage Power Capacitors Vishay ESTA

Vishay Electronic GmbH

Division Roederstein
ESTA und Hybride
Hofmark-Aich-Strasse 36
D-84030 Landshut
Germany

Phone: + 49 871 86-0

Fax: + 49 871 862519

www.vishay.com

NOTICE

The information in this catalog has been carefully checked for accuracy, and though it is believed to be correct, no warranty, either express or implied, is made as to either its applicability to, or its compatibility with, specific requirements; nor does Vishay Intertechnology, Inc. and its affiliates assume any responsibility for correctness of this information, nor for damages consequent to its use.

All such printed materials are not legally binding unless confirmed in writing pursuant to §§463 and 480 11 of the German Code of Civil Law.

Warning Regarding Life Support Applications

Not all products listed in this catalog are generally recommended for use in life support systems where a failure or malfunction of the component may directly threaten life or cause injury.

The user of products in such applications assumes all risks of such use and will agree to hold Vishay Intertechnology, Inc. and all the companies whose products are represented in this catalog, harmless against all damages.



High Voltage Power Capacitors

Contents	1
General Information	2
Bushings	6
Request for Quotation	7
Pha...Power Capacitors	9
Capacitor Assembly	11
Quality Assurance Certificate	14
ESTA Products	15

High Voltage Power Capacitors

SCOPE

Single phase capacitor units from 1kV up to maximum 24kV, 50 or 60Hz, 20kVAR up to maximum 1000kVAR

for indoor or outdoor use.

- with dead casing, open terminal IP00 (2 bushings)
- with dead casing, type of enclosure IP55 (2 bushings)
- with live casing, open terminal IP00 (1 bushing)

Three phase capacitor units from 1kV up to maximum 12kV, 50 or 60Hz, 20kVAR up to max. 800kVAR with pressure monitoring device.

- with dead casing (3 bushings), open terminal IP00 (indoor use only)
- with dead casing (3 bushings), protected terminals, type of enclosure IP55 (indoor or outdoor)

STANDARDS

- VDE 0560/4 "Bestimmungen für Leistungs-Kondensatoren"
- IEC 60871-1 Power Capacitors
- IEC 143 'Series capacitors for power systems
- AS 2897 Shunt Capacitors for connection to Power frequency systems
- ANSI IEEE Std 18 Shunt power capacitors
- NEMA CP-1 Shunt Capacitors
- CSA C22.2 No.190 'Capacitors for power factor correction
- BS 1650 Specification for Capacitors for connection to power frequency systems

Capacitors in accordance with other standards, available upon request.

QUALITY MANAGEMENT SYSTEM

ISO 9001, BS 5750

QUALIFICATIONS

- EDF (HN 54-S-05)
- CSA Std. C22.2 No 190-M1985

SAFETY REGULATIONS

When installing the equipment, relevant ICE or VDE recommendations shall be observed, in particular VDE 0101 and 0111, as well as VDE 0560 Part 4 Section C.

Quality management system: ISO 9001, BS 5750

Qualifications: EDF (HN 54-S-05), CSA

FIELDS OF APPLICATION

POWER FACTOR CORRECTION

The active power produced by the active current can alone be turned into an effective use for the consumer; while the reactive power produced by the reactive current does not yield usable power, and consequently, is not registered on the active performance meter. The reactive power has, however, a negative effect on generators, transformers, and conductor lines, while causing voltage drops and financial losses due to additional electric heating.

The reactive power required for the creation of the magnetic fields around motors, transformers, and conductor lines continuously oscillates between the current generators and the consumers. A more cost effective way to provide this reactive power is to produce it by placing capacitors close to the consumers of reactive power (motors, transformers), thus relieving the line between generator and consumer of the transport of the reactive current portion. This way, several more current consumers can be connected to an existing supply system without having to extend or amplify that system if the capacitors are suitably positioned.

Individual Power Factor Correction

The power factor correction capacitor is connected directly to the terminals of the consumer and will be switched together with it. The advantages of this method are: Relief of the conductor lines and switches, no capacitor switches or discharge resistors are needed, and the installation is simple and cheap. The individual compensation is the best solution for large consumers (e.g. motors), particularly if they are in continuous operation.

Individual Power Factor Correction of 3-Phase Motors

The motor and the capacitor are connected in parallel. They are both switched in and out by means of one and the same switchgear and also monitored by a common protective device. A discharge device is not required, because discharging takes place through the motor windings.

The switchgear must be rated to be capable of withstanding the inrush current of the capacitor and the connection lines must be capable of withstanding the full load current of the motor. The capacitor, in this case, has to be installed in close proximity to the motor.

Individual Power Factor Correction of Power Transformers

The direct connection of the capacitor to a power transformer, which is jointly switched in and out, is feasible and permissible both at the H.V. side and the L.V. side.

In cases where harmonics exist in the line, the line should be checked to determine whether the capacitors and the power transformer are connected in series and create a resonance.

Care should be taken not to overcompensate the power transformer during low load operation in order to avoid an unacceptable rise in voltage.

Individual Power Factor Correction of Welding Machines

The output of capacitors for welding transformers and resistance welding machines only needs to be in the range of 30% to 50% of the nominal transformer capacity. For welding rectifiers, a capacitor output of about 10% of the nominal capacity of the transformer/rectifier is sufficient.

Group Power Factor Correction

The power factor correction capacitor is connected to the secondary distribution system which feeds a number of individual motors, operating either continuously or at intervals.

The motors and the capacitors are each switched in and out separately and are monitored by separate protective devices. The capacitors can be switched in or out individually or in groups.



Central Power Factor Correction

In large installations where many individual electrical appliances of various size (motors etc.) operate at different times and for different periods, the power factor correction capacitors are centrally connected to the main buss bar. The capacitors can be switched either manually or, by means of power factor control relays, automatically.

Advantage

Automatic control and optimal matching of the capacitor output to the specific requirements for reactive power insures that the specified cos phi is maintained in the most cost effective way.

Disadvantage

The conductor lines between the buss bar and electrical appliances are not relieved of the reactive current.

D General Data

Dielectric

An all film dielectric is used and consists of polypropylene in the form of biaxially oriented film, hazy on both side, and in 2 or 3 layers with a laser cut aluminium foil for the electrodes.

Impregnating Agent

The capacitors are impregnated with a NON-PCB based fluid.

Dielectric Losses and Total Losses

Dielectric losses in new state are approx. 0.1W/kVar and reduce after 500 operating hours to a stable state of approx. 0.02 to 0.05W/kVar (see curve 1 and curve 2).

The dielectric losses, depending on capacitor design, shall be added to the losses caused by:

- discharge resistors
- internal connections
- internal fuses

Total losses will reach values from 0.07 to approx. 0.15W/kVAR.

Testing

Capacitors are tested in accordance with IEC-Standard 60871-1

Other standards upon request.

Curve 1

Losses as a function of operating time

Losses=f(t)

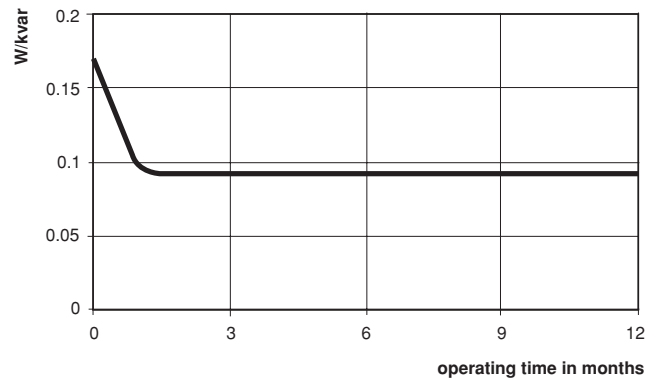

Losses variation of a representative capacitor unit

Curve 2

Losses as a function of dielectric temperature

Losses=f(T)

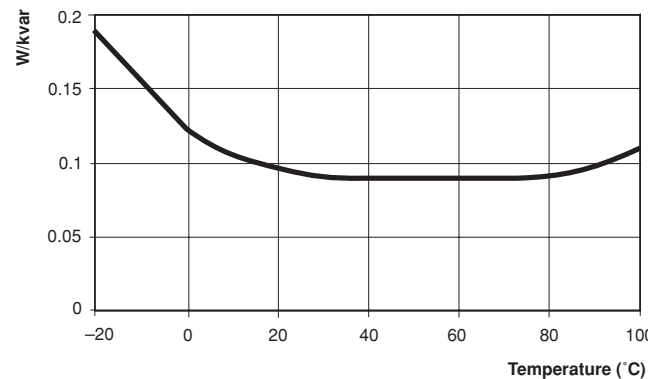

Curve 3

Capacitance as a function dielectric temperature

Capacitance=f(T)

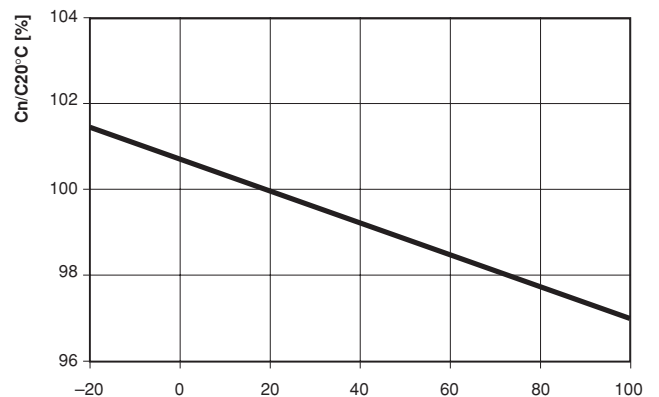

Temperature Range

Capacitors are classified in temperature categories, with each category being specified by a number followed by a letter.

SYMBOL	AMBIENT AIR TEMPERATURE (°C)		
	MAXIMUM	HIGHEST MEAN OVER ANY PERIOD OF	
		24 HOURS	1 YEAR
A	40	30	20
B	45	35	25
C	50	40	30
D	55	45	35

The number represents the lowest ambient air temperature at which the capacitor may operate.
The letters represent upper limits of temperature variation ranges, having maximum values specified in above table.

Overloads

a) Maximum permissible voltage (continuous)

Capacitor units shall be suitable for operation at voltage levels according to the following table.

The amplitudes of the over voltages that may be tolerated without significant deterioration of the capacitor depend on the duration, the total number and the capacitor temperature.

TYPE	VOLTAGE FACTOR (t.m.s)	MAXIMUM DURATION	OBSERVATION
Power frequency	1.0U _N	continuous	Highest average value during any period of capacitor energization. For energization periods less than 24h, exceptions apply in accordance with the value below
	1.1U _N	12h in every 24h	System voltage regulation and fluctuations
	1.15U _N	30 min in every 24h	System voltage regulation and fluctuations
	1.2U _N	5 min	Voltage rise at light load
	1.3U _N	1 min	

b) Maximum permissible current

Capacitor units shall be suitable for continuous operation at an r.m.s. current of 1.30 times the current that occurs at rated sinusoidal voltage and rated frequency, excluding transients.

Discharging

Following may be used as discharge device:

- discharge resistors
- discharge coils
- discharge transformers
- windings of motors or transformers

Each capacitor unit shall be provided with means for discharging to 75V or less.

Corrosion Protection

Case material: stainless steel (ref.: 4512)

Pre-treatment:

- pickling with acid
- washing with water
- alkalinous degreasing
- washing with water
- washing with distilled water

First coating: two-component agent on polyacryl basis, (Percotex LA-Universal green)

Top coating: Dedelan, two component agent on acryl-polyurethan basis (color RAL 7033)

Coating thickness: total 50-60µm

Protection Devices for Power Capacitors

Detailed information is provided in IEC 60871-3 "Protection of shunt capacitors and shunt capacitor banks."

a) Internal Fuses

Detailed information is provided in IEC 60871-4 "Internal fuses."

Internal fuses are designed to isolate faulty elements in order to allow further operation of the capacitor unit and the bank in which the capacitor is connected.

Complete protection is obtained when using internal fuses together with an unbalance protection device.

b) Pressure Monitoring Device

The pressure inside the capacitor casing is monitored by means of an over pressure sensor. In the event that the setting (critical value) is exceeded, a change-over contact initiates disconnection of the capacitor. Such an early disconnection from the source of supply after an internal breakdown can stop gas evolution in the capacitor casing, avoiding the bursting of it.

Complete protection is obtained when using the pressure monitoring device together with H.R.C. fuses.

Technical Data

Casing:	Bakelite, resistant up to 100°C
Electrical connection:	AMP-plug type lugs 6.35mm
Contacts:	1 change-over contact 15 A/220V ohmic load
Insulation test voltage:	1500V
Setting range:	0.2 - 0.9 bar
Standard setting:	0.6 - 0.8 bar
Pressure limit:	6.0 bar
Accessory:	rubber protective cap
Temperature range:	- 25° up to + 70°C
Dimension:	see dimension
Fitting:	R 1/4" and mechanical protection
Mounting position:	dependant on design of capacitor
Testing:	functional test and leakage test

Important ! If the pressure monitoring device has operated, the capacitor must not be placed back into service, but returned together with the device to our factory for examination.

EXAMPLES OF MOUNTING:

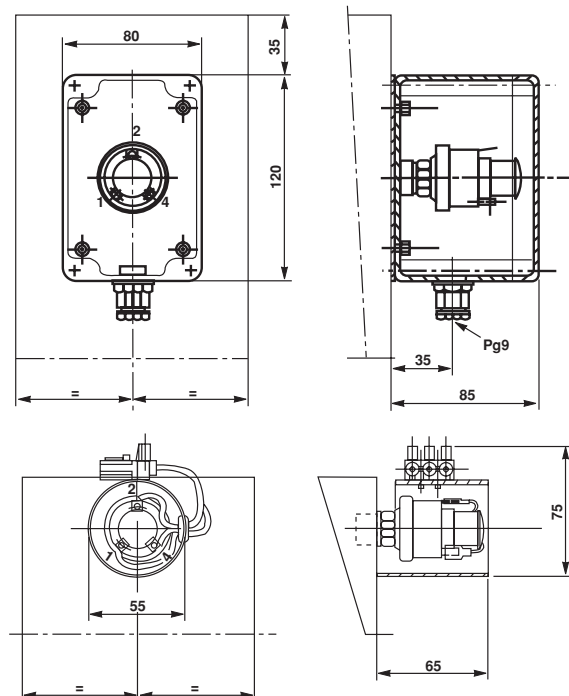

High Voltage Power Capacitors

BUSHINGS

Porcelain bushings for indoor and outdoor

TYPE	IMPULSE WITHSTAND BIL (kV)	MIN. CREEPAGE (mm)	INSTALLATION	HEIGHT (mm)	MAX. TORQUE N/m
D-197	–	90	indoor	75	16Nm
D-199	75	189	indoor	159	20Nm
D-210	110	317	outdoor	232	40Nm
D-211	150	457	outdoor	264	40Nm
D-212	175	635	outdoor	283	40Nm
D-213	175	711	outdoor	362	40Nm

DRAWINGS OF BUSHINGS

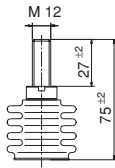

D-197

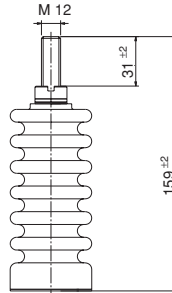

D-199

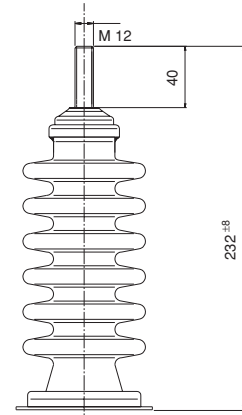

D-210

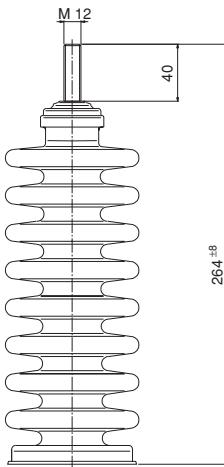

D-211

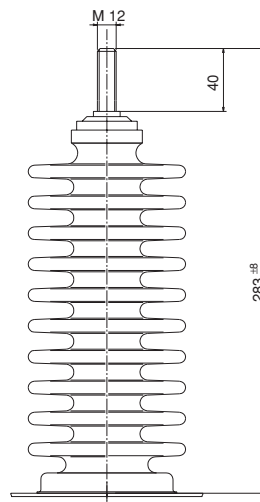

D-212

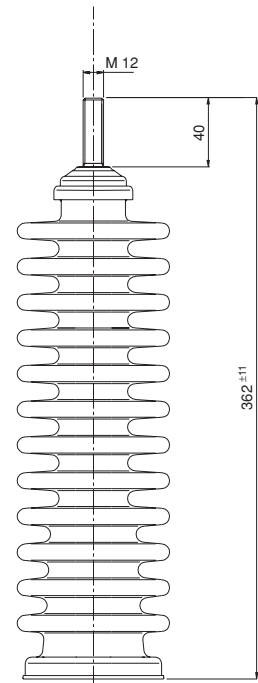

D-213



High Voltage Power Capacitors

REQUEST FOR QUOTATION			
PRODUCT GROUP	HIGH VOLTAGE CAPACITOR		
REQUEST FOR QUOTATION			
REFERENCE FOR INQUIRY			
QUOTATION NUMBER			
TECHNICAL SPECIFICATION			
		REQUESTED	OFFERED
RATED VOLTAGE*	KV		
FREQUENCY*	HZ		
RATED OUTPUT*	KVAR		
CONNECTION	SINGLE PHASE/THREE PHASE		
NUMBER OF BUSHINGS*	1 / 2 / 3		
INSTALLATION*	INDOOR / OUTDOOR		
CAPACITANCE	μF		
ELEMENT FUSE	YES / NO		
DISCHARGE RESISTOR	YES / NO		
STANDARD			
TEMPERATURE CLASS	-...../+.....°C		
INSULATION LEVEL	KV / KVP		
ENCLOSURE			
PROTECTION	IP..		
DIMENSION L X W X H	(MM)		
REPLACEMENT	YES / NO		
IF YES, WHAT TO REPLACE			
DIMENSIONS	L X W X H (MM)		
PRESSURE MONITORING	YES / NO		
* = NO QUOTATION POSSIBLE WITHOUT THIS INFO			
CONDITIONS			
QUANTITY			
DELIVERY	(EX WORKS/FOB/CIF...)		
TERMS OF PAYMENT			
REQUESTED VALIDITY			
REQUESTED DELIVERY			

Request For Quotation

Vishay ESTA

High Voltage Power Capacitors



REQUEST FOR QUOTATION			
PRODUCT GROUP	HIGH VOLTAGE CAPACITOR BANK		
REQUEST FOR QUOTATION			
REFERENCE FOR INQUIRY			
QUOTATION NUMBER			
TECHNICAL SPECIFICATION			
		REQUESTED	OFFERED
RATED VOLTAGE*	KV		
FREQUENCY*	HZ		
RATED OUTPUT*	MVAR		
INSTALLATION*	INDOOR / OUTDOOR		
CONNECTION*	SINGLE PHASE, STAR, DELTA		
CAPACITANCE	µF		
UNBALANCE PROTECTION	YES / NO		
ELEMENT FUSE	YES / NO		
DISCHARGE RESISTOR	YES / NO		
STANDARD			
TEMPERATURE CLASS	-...../+.....°C		
INSULATION LEVEL	KV / KVP		
ENCLOSURE			
PROTECTION	IP...		
REPLACEMENT	YES / NO		
IF YES, WHAT TO REPLACE			
* = NO QUOTATION POSSIBLE WITHOUT THIS INFO			
CONDITIONS			
QUANTITY			
DELIVERY	(EX WORKS/FOB/CIF...)		
TERMS OF PAYMENT			
REQUESTED VALIDITY			
REQUESTED DELIVERY			

High Voltage Power Capacitors

FORM OF CONSTRUCTION



In the case of single phase capacitor units with dead casings, both polarities are led out through the casing in an insulated condition by means of porcelain bushings (Fig.1).



In the case of single phase capacitor units with one bushing only, the second polarity is connected to the casing (Fig.2).



Three-phase capacitors are provided with three bushings for connection to the phases and have dead casings with grounding connection point (Fig. 3). They are connected either in star or in delta.



In cases where protection against an accidental touch is required, the capacitors can be supplied as IP 55 version (Fig. 4).

CAPACITOR - DIMENSION AND WEIGHT

• Three-phase capacitor up to 7.2kV, 50Hz, IP00

OUTPUT QN kVAr	WEIGHT kg	CASING DIMENSIONS			
		L	x	I	x H
50	21	345	x	110	x 300 mm
75	21	345	x	110	x 300 mm
100	22	345	x	110	x 300 mm
133	24	345	x	110	x 350 mm
150	27	345	x	110	x 410 mm
167	29	345	x	110	x 430 mm
200	32	345	x	135	x 430 mm
250	37	345	x	135	x 500 mm
300	41	345	x	175	x 450 mm
350	47	345	x	175	x 520 mm
400	53	345	x	175	x 600 mm
450	56	345	x	175	x 640 mm
500	62	345	x	175	x 710 mm
550	67	345	x	175	x 770 mm
600	71	345	x	175	x 820 mm
650	78	345	x	175	x 910 mm
700	81	345	x	175	x 950 mm
750	101	345	x	270	x 810 mm
800	106	345	x	270	x 850 mm

• Three-phase capacitor up to 12kV, 50Hz, IP00

OUTPUT QN kVAr	WEIGHT kg	CASING DIMENSIONS			
		L	x	I	x H
50	25	450	x	110	x 300 mm
75	25	450	x	110	x 300 mm
100	27	450	x	110	x 320 mm
133	30	450	x	110	x 400 mm
150	35	450	x	110	x 430 mm
167	37	450	x	110	x 470 mm
200	43	450	x	110	x 540 mm
250	49	450	x	110	x 620 mm
300	58	450	x	110	x 750 mm

• Three-phase capacitor up to 12kV, 50Hz, IP55

OUTPUT QN kVAr	WEIGHT kg	CASING DIMENSIONS			
		L	x	I	x H
50	24	345	x	135	x 300 mm
75	24	345	x	135	x 300 mm
100	24	345	x	135	x 300 mm
133	29	345	x	135	x 330 mm
150	30	345	x	135	x 360 mm
167	29	345	x	135	x 380 mm
200	32	345	x	135	x 430 mm
250	37	345	x	175	x 400 mm
300	43	345	x	175	x 480 mm
350	48	345	x	175	x 540 mm
400	52	345	x	175	x 590 mm
450	57	345	x	175	x 650 mm
500	61	345	x	175	x 700 mm
550	69	345	x	175	x 810 mm
600	74	345	x	175	x 870 mm
650	78	345	x	175	x 920 mm
700	83	345	x	175	x 980 mm
750	105	345	x	270	x 840 mm
800	109	345	x	270	x 880 mm

• Single-phase capacitor up to 7.2kV, 50Hz

OUTPUT QN kVAr	WEIGHT kg	CASING DIMENSIONS			
		L	x	I	x H
200	31	345	x	110	x 490 mm
300	41	345	x	175	x 450 mm
400	50	345	x	175	x 575 mm
500	60	345	x	175	x 698 mm
600	70	345	x	175	x 820 mm
700	80	345	x	175	x 950 mm
800	90	345	x	175	x 1090 mm
900	99	345	x	270	x 810 mm
1000	108	345	x	270	x 950 mm

• Single-phase capacitor up to 12kV, 50Hz

OUTPUT QN kVAr	WEIGHT kg	CASING DIMENSIONS			
		L	x	I	x H
200	31	345	x	175	x 325 mm
300	40	345	x	175	x 450 mm
400	50	345	x	175	x 570 mm
500	60	345	x	175	x 705 mm
600	70	345	x	175	x 830 mm
700	80	345	x	175	x 950 mm
800	90	345	x	175	x 1090 mm
900	99	345	x	270	x 810 mm
1000	109	345	x	270	x 895 mm

High Voltage Power Capacitors

TYPICAL ARRANGEMENTS

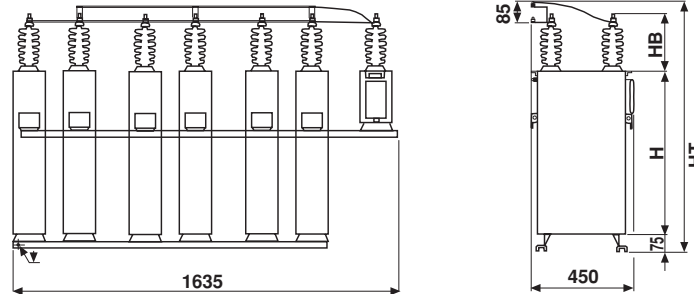

Type: G00S31

Maximum voltage: 24kV

Installation: indoor or outdoor

Connection: double star with unbalanced protection device

Protection level: IP 00

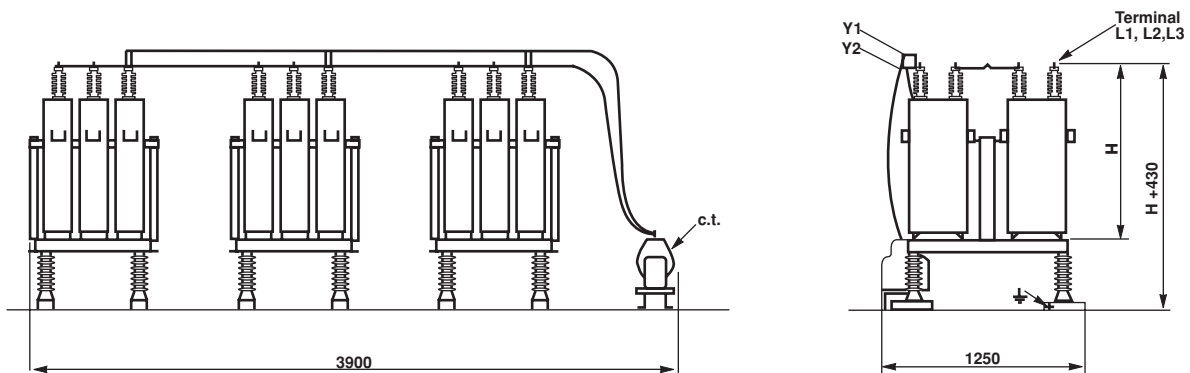

Type: G00S12

Voltage: > 24kV

Installation: indoor or outdoor

Connection: double star with unbalanced protection device

Protection level: IP 00

Capacitor Assembly

Vishay ESTA

High Voltage Power Capacitors



TYPICAL ARRANGEMENTS

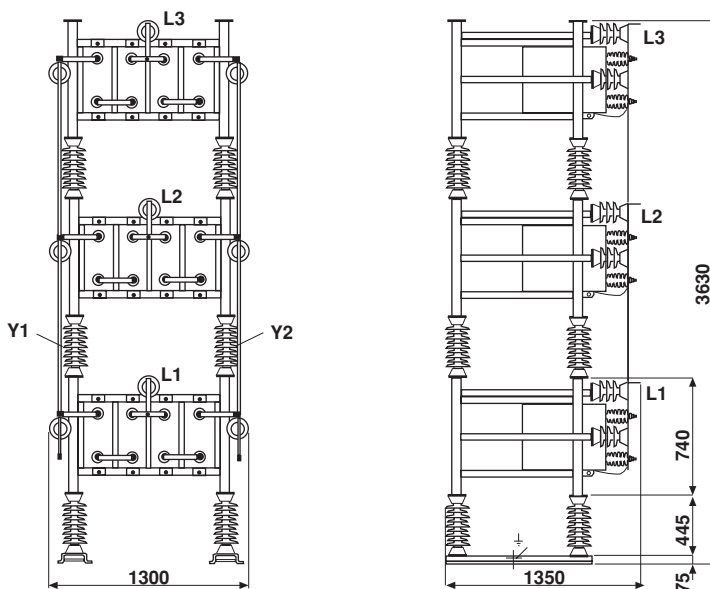

Type: G00L11

Voltage: > 24kV

Installation: indoor or outdoor

Connection: double star

Protection level: IP 00

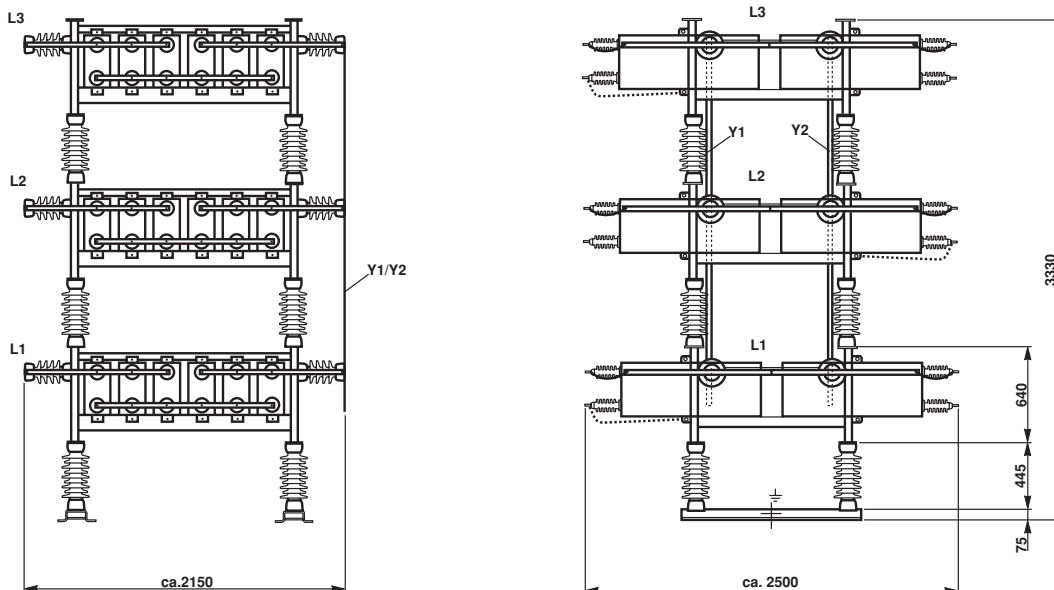

Type: G00L12

Voltage: > 24kV

Installation: indoor or outdoor

Connection: double star

Protection level: IP 00

TYPICAL ARRANGEMENTS

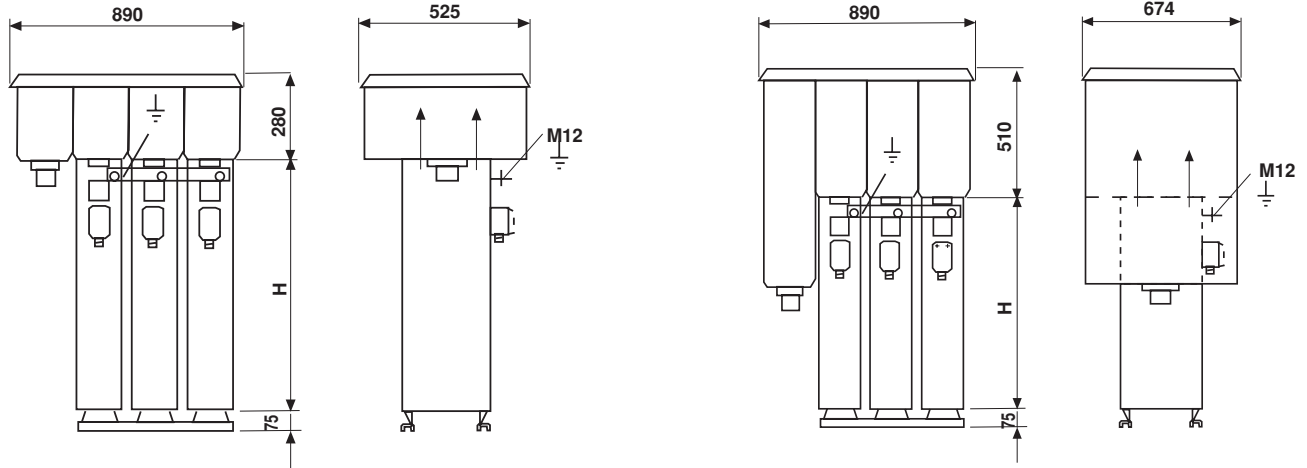

Type: H55S31-3/D/K1PG68
 Maximum voltage: 7.2kV
 Installation: indoor or outdoor
 Connection: star or delta with pressure monitoring device
 Protection level: IP 55

Type: H55S31-3/D/G1PG68
 Maximum voltage: 12kV
 Installation: indoor or outdoor
 Connection: star or delta with pressure monitoring device
 Protection level: IP 55

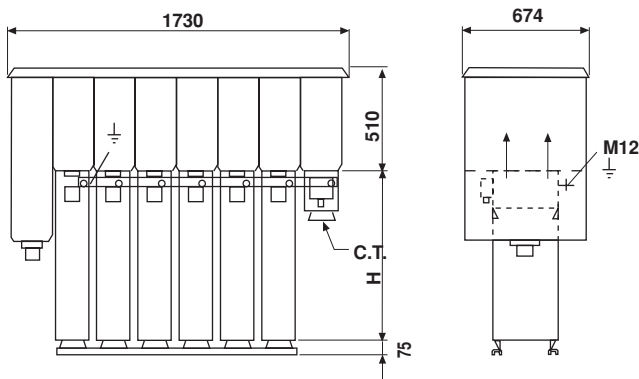

Type: H55S31-6/U/G1PG68
 Maximum voltage: 12kV
 Installation: indoor or outdoor
 Connection: double star with unbalanced protection device
 Protection level: IP 55

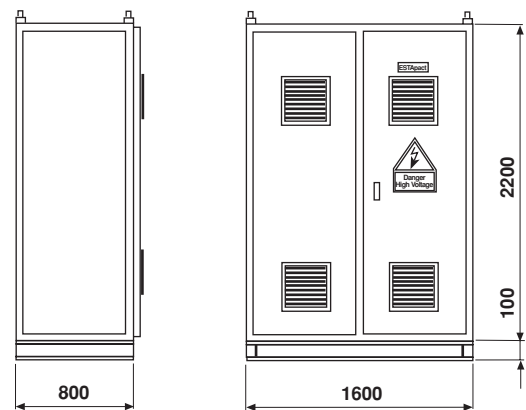

Type: S43S31
 Maximum voltage: 12kV
 Installation: indoor only
 Protection level: IP 43

CERTIFICATE

Registration-Number: 2556/QM/03.94

This is to certify that the company

VISHAY

VISHAY ELECTRONIC GmbH
Division ESTA

at the following locations

Riegrova 1231, CZ-38801 Blatna
Pasticka 1243, CZ-38801 Blatna
Hofmark-Aich-Straße 36, D-84030 Landshut

has implemented and maintains a
Quality-Management System for the following scope:

Heavy Current Capacitors
High Voltage Units

This QM-System complies with the requirements of:

DIN EN ISO 9001:2000

This Certificate is valid until 19.03.2006

VDE Testing and Certification Institute
Certification



D-63069 Offenbach/Main, Merianstraße 28
Date: 02.04.2003
2556-9110-0004/27625

The VDE Testing and Certification Institute is accredited by DAR Accreditation Bodies according to DIN EN 45012 and notified in the EU under ID. No. 0366.



FLUORESCENT LAMP/MOTOR CAPACITORS



POWER-FACTOR CONTROLLER



FURNANCE CAPACITORS



POWER ELECTRONIC CAPACITORS



LOW VOLTAGE CAPACITOR SYSTEMS



HIGH-VOLTAGE CAPACITORS

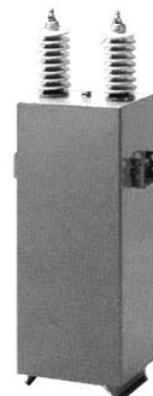







WORLDWIDE SALES CONTACTS

DISCRETE SEMICONDUCTORS AND PASSIVE COMPONENTS

THE AMERICAS

VISHAY AMERICAS

2100 WEST FRONT STREET
STATESVILLE, NC 28677
UNITED STATES
PH: +1-704-872-8101
FAX: +1-704-873-8847

ASIA

VISHAY INTERTECHNOLOGY ASIA PTE LTD.

25 TAMPINES STREET 92
KEPPEL BUILDING #02-00
SINGAPORE 528877
PH: +65-6788-6668
FAX: +65-6788-0988

JAPAN

VISHAY JAPAN CO., LTD.

SHIBUYA 3F, GE EDISON BUILDING
3-5-16 SHIBUYA
SHIBUYA-KU
TOKYO 150-0002
JAPAN
PH: +81-3-5464-6411
FAX: +81-3-5464-6433

EUROPE

VISHAY ELECTRONIC GmbH

GESCHÄFTSBEREICH ROEDERSTEIN
ESTA UND HYBRIDE
HOFMARK-AICH-STRASSE 36
84030 LANDSHUT
GERMANY
PH: +49-871-86-0
FAX: +49-871-77-01-52

VISHAY S.A.

4, RUE DE SALONIQUE
95101 ARGENTEUIL
FRANCE
PH: +33-1-39-98-22-00
FAX: +33-1-39-98-22-05

VISHAY LTD.

PALLION INDUSTRIAL ESTATE
SUNDERLAND, SR4 6SU
GREAT BRITAIN
PH: +44-191-514-4155
FAX: +44-191-567-8262

ONLINE INFORMATION

For product information and a current list of sales reps and distributors, visit our website:

www.vishay.com

ONE OF THE WORLD'S LARGEST MANUFACTURERS OF DISCRETE SEMICONDUCTORS AND PASSIVE COMPONENTS



VISHAY INTERTECHNOLOGY, INC.

World Headquarters

63 Lincoln Highway

Malvern, PA 19355-2143

United States

www.vishay.com

© Copyright Vishay Intertechnology, Inc.
Registered Trademarks of Vishay Intertechnology, Inc.
All rights reserved. Printed in the United States
Specifications subject to change without notice.

Databook VSD-DB0053-0210